

Assembly and installation instructions for Triton's Pivoting
Wall-Mount Tool Storage
For
System Style: Single Panel Series B1 and B1-2
(Rev. 03/05)

Finished size per panel 24" Wide x 48" High

Notice

Read all instructions completely before installing. Should you have any questions about your installation please call customer service toll-free at 877-963-2990

NOTE: All systems must be secured to structurally sound, flat walls

Step 1. Remove all parts from carton and inventory all components.

Parts Inventory (For B1-2 Part Qty. Will Double)

- (1) Panel frame section 24" w X 48" h black (31" Wide @ arm extensions)
- (2) Sheets of 1/4" tempered peg-board with 1" on center (O.C.) hole spacing
- (2) Wall mount angle plates 3" X 3" X 4" long.
- (4) 1/4" X 1-3/4" Phillips flat head masonry screws (for wall mounting angle attachments)
- (2) 3/8"-16 x 2-1/4" hex head bolt (pivoting pins)
- (4) 3/8" flat washers (for pivoting pins)
- (4) 3/8"-16 hex head nuts (for pivoting pins)
- (2) 3/8" Lock washer (for pivoting pins)
- (28) 3/4" self tapping truss screws with #2 Phillips head (for tempered peg-board attachment)
- (2) Plastic end caps

Step 2. Pivoting bolt attachment to arm assemblies: (Refer to figure 1-2 close-up.) Using 3/8"-16 x 2-1/4" hex bolts, slide (1) 3/8" washer onto bolt and then insert bolt with washer through hole in arm assembly. Once through arm assembly, install another flat washer and secure using (1) 3/8" hex nut by hand tightening. **Repeat steps for second arm.**

Step 3. Attaching tempered peg-board to each side of frame: Using the existing holes in peg-board and #10-3/4" self-tapping screws. Square up peg-board with the outside edge of your frame section. Using an electric drill with a high performance #1 or #2 Phillips bit, install self-tapping screws into each of the corners opposite arm assemblies; complete installation using (figure 1-1 for tap screw layout. **Repeat step for other side.** To help expedite installation of your peg-board: You may want to pre-drill where tap screws are to be installed using a 1/8" drill bit.

Step 4: Plastic end caps. Insert plastic end caps into the remaining open ends of you tubular frame. *(Caps do not install on the open ends of the extension arms.)*

Note: Before starting step 5, it will be necessary to determine if your walls are plumb and structurally sound. It may be necessary to install some type of shim system or header for either or both, top and bottom wall

brackets. (For 2"X4" studed walls refer to figure 1-4 for header installation.)

Step 5. Bottom wall mount bracket Installation for concrete walls (refer to figure 1-1 & 1-2): Each bracket/angle has been pre-drilled for wall and panel attachment. You will be installing your bottom bracket first. **A)** Determine the appropriate height you want to install off the floor or work surface. **B)** Using one angle bracket as your template, with surface having only one hole on top and flat surface with two holes against the wall at the desired height. (**Avoid mortar joints between concrete blocks.**) **C)** Making sure wall mount bracket is level; mark both hole locations on the wall. **D)** Using 3/16" masonry bit and hole location markings on the wall, drill two holes 1-1/4" in depth. **Do Not Ream Out or Oversize the holes** **E)** Align bracket back over holes drilled and using a #2 Phillips head bit and electric drill set at medium speed, install (2) 1/4" x 1-1/4" masonry screws. . **WARNING: Over tightening could cause holes to become oversized. If holes become enlarged: You must properly repair and re-drill, relocate mounting brackets or install a wood header.** For 2x4"studded walls refer to figure 1-4 for installation.

Step 6: Installation of top wall bracket: (Refer to Figure 1-1 and 1-2) top surface of this bracket will be placed 47" from the top of your mounted bottom bracket and aligned with it (Plum). **Repeat step 5 for proper installation of top bracket.**

Step 7: Attaching panels to wall mount brackets. (Refer to figure 1-1 & 1-2) Align panels pivoting bolts with holes in the top surface of each bracket and insert through. Install 3/8" lock washer and 3/8"-16 hex head nuts on both pins and tighten thoroughly. Make sure that the bottom 3/8" hex head nut attached to each arm comes in contact with the top each wall bracket. If one of the hex head nuts still does not make contact, uninstall panel from brackets and insert 1-2 Maximum 3/8" flat washers between the pivoting arm and its bottom 3/8" hex head nut. (Additional washers not included.)

Step 8: Side by side panel installations. (Figure 1-3) Panels should be mounted 16" to 18" (On Center) O.C. to prevent tools from coming in contact with each other. **(For P/N B1-2 Double panel system repeat steps 2-7)**

Installing to other than concrete walls

When installing a system to other types of wall structures it is recommended that a 2" x 6" header be securely installed to multiple studs and that 1/4" lag bolts be used in place of the supplied masonry bolts to attach wall brackets. (Refer to Figure 1-4 for header installation)

Swing tension adjustment

Due to unevenness of walls or mounting brackets installation, it is some times necessary to increase the tension on the pivoting arms. First try tightening the 3/8" hex head nut mounted on the underneath side of your mount brackets. If this does not work then loosen nut below bracket and tighten nut above bracket counter clockwise against arm assemblies and then re-tighten nut below mount brackets.

To View Triton's Full Line of Storage Systems and Products Go To
www.tritonproducts.com

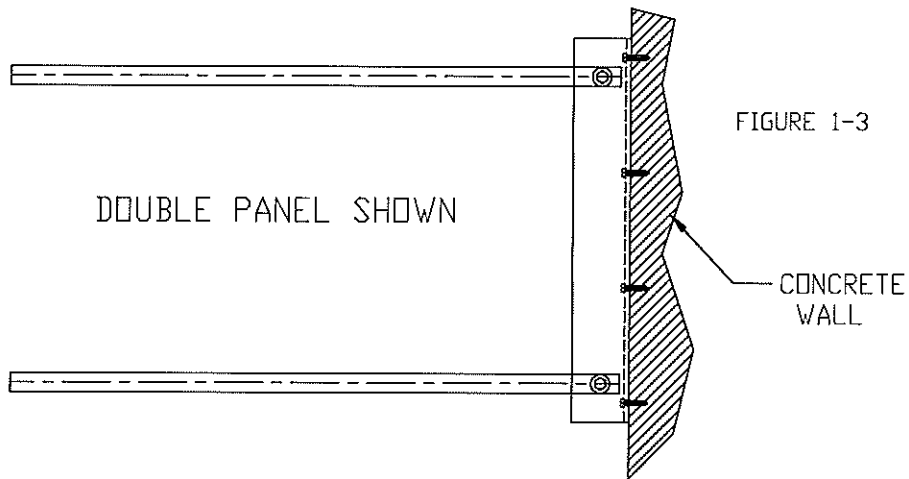

FIGURE 1-3

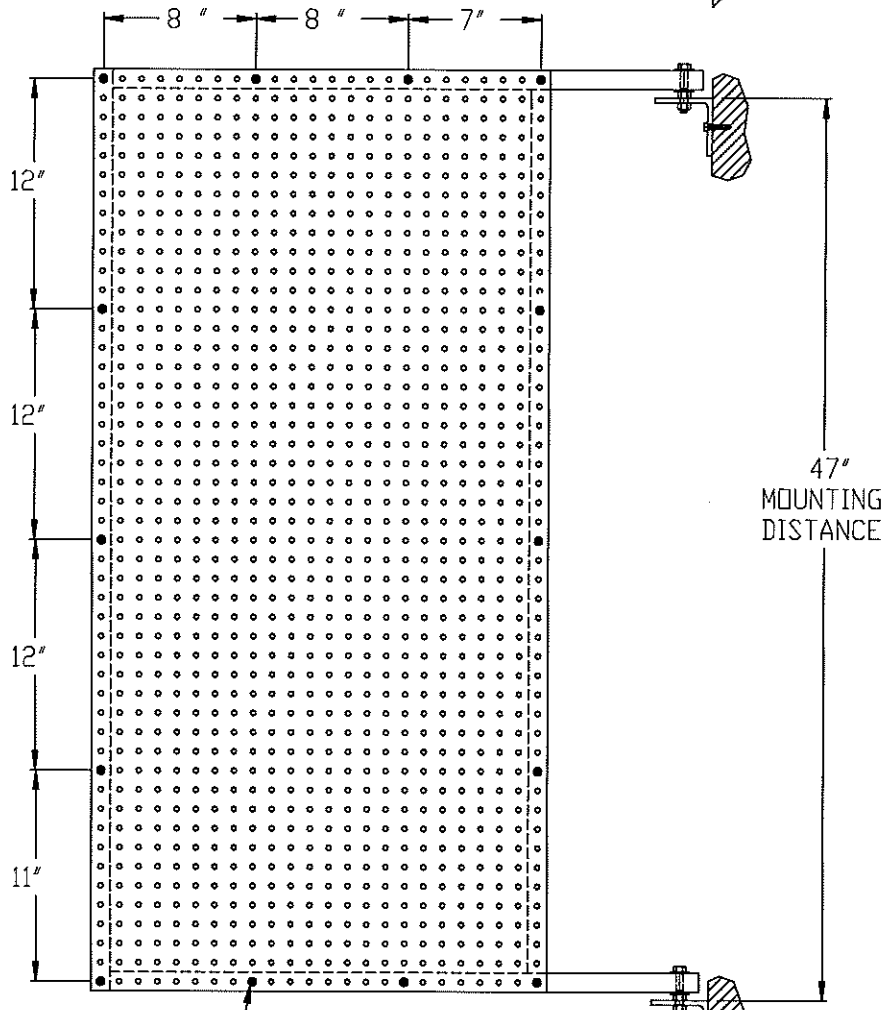
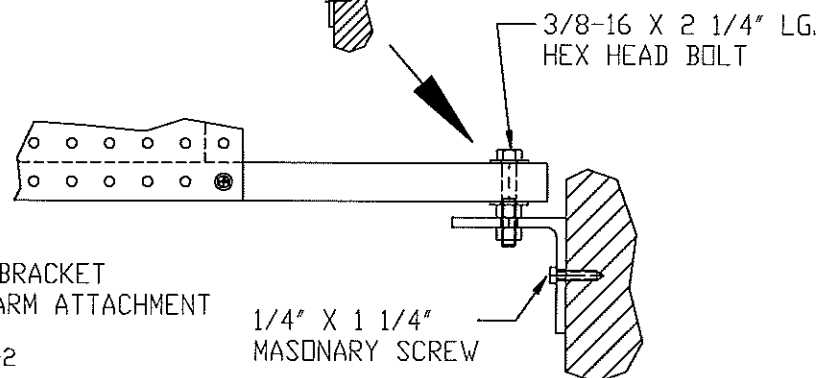

FIGURE 1-1

#10 X 3/4" LG.
SELF TAPPING SCREW
ATTACH USING EXISTING
PEGBOARD HOLES

WALL MOUNT BRACKET
AND PANEL SWING ARM ATTACHMENT

FIGURE 1-2



1/4" X 1 1/4"
MASONRY SCREW